



MiniTec Facts & figures

THE ART OF SIMPLICITY

MiniTec has continuously developed from a specialist for miniature guides to a leading technology company and special equipment manufacturer

Today 400 experts at 11 locations in Germany, France, USA, United Kingdom, Spain, Slovenia and China develop tailor-made solutions for our customers. At the same time, more than 60 partners worldwide ensure reliable service and competent technical support.

Our solutions are just as individual as our customers' requirements. As a full-service manufacturer, we use our design system to implement intelligent systems and special machines for a wide variety of tasks in all important industrial sectors: from automotive, chemicals and electrical engineering to energy supply, aerospace, mechanical engineering, the metal and pharmaceutical industries.



1986
Founded



420
Employees
280 in Germany



60
Sales and service partners
around the world



Business award
„Innovativer Mittelstand“
Award
„Attraktiver Arbeitgeber
Rheinland-Pfalz“
Honorary award
of the region Westpfalz
Hidden Champion



11
Locations
Germany, France, Slovenia,
United Kingdom, Spain, USA,
China

LOCATIONS WORLDWIDE

MINITEC GMBH & CO. KG (GERMANY)

MiniTec Allee 1 | 66901 Schönenberg-Kübelberg
Tel. +49 6373 81270 | Fax +49 6373 812720
info@minitec.de | www.minitec.de

MINITEC GMBH & CO. KG (GERMANY)

Nickelsweiher 6 | 66914 Waldmohr
Tel. +49 6373 81270 | Fax +49 6373 812720
info@minitec.de | www.minitec.de

MINITEC GMBH & CO. KG (GERMANY)

Fürther Straße 33 | 90513 Zirndorf
Tel. +49 911 2789000 | Fax +49 911 27890099
zirndorf@minitec.de | www.minitec.de

MINITEC SMART SOLUTIONS GMBH (GERMANY)

Zollamtstraße 7 | 67663 Kaiserslautern
Tel. +49 6373 8127 350 | Fax +49 6373 812720
kontakt@mss-digital.de | www.minitec-smart-solutions.net

MINITEC BERLIN GMBH (GERMANY)

Volmerstraße 13 | 12489 Berlin
Tel. +49 30 2359 8000
berlin@minitec.de | www.minitec.de

MINITEC ESPAÑA S.L.U. (ESPAÑA)

C/ Carlos Jiménez Díaz, 7. Pol. Ind. La Garena
28806 Alcalá de Henares, Madrid
Tel. +34 916 562 652
info@minitec.es | www.minitec.es

MINITEC S.N.C. (FRANCE)

2, rue Charles Desgranges | 57214 Sarreguemines
Tel. +33 387 276870 | Fax +33 387 276877
info@minitec.fr | www.minitec.fr

MINITEC.AT GMBH (AUSTRIA)

Beethovenstraße 12 | 2380 Perchtoldsdorf
Tel. +43 1 8659559
office@minitec.at | www.minitec.at

MINITEC 4NAG (SWITZERLAND)

Honeywell-Platz 1 | 8157 Dielsdorf
Tel. +41 44 5751500 | Fax +41 44 5751501
info@minitec.ch | www.minitec.ch

MINITEC SOLUTIONS SRL ROMÂNIA (ROMÂNIA)

Str. I.H. Pestalozzi Nr. 22 | Timisoara 300115
Tel. +40 722 229 134
office@minitec.ro | www.minitec.ro

MINITEC D.O.O. (SLOVENIJA)

Teharska cesta 41 | 3000 Celje
Tel. +386 59 071 390 | Fax +386 59 071 399
info@minitec.si | www.minitec.si

MINITEC SLOVAKIA S.R.O. (SLOVENSKO)

Rabčická 332 | 029 44 Rabča
Tel. +421 43 5524350 | Fax +421 43 5524352
info@minitec-slovakia.sk | www.minitec-slovakia.sk

MINITEC HELLAS S.A. (GREECE)

Ag. I. Theologou 115 | 13672 Acharnes, Athen
Tel. +30 210 2401444
info@minitechellas.gr | www.minitechellas.gr

MINITEC UK LTD. (UNITED KINGDOM)

Unit 1A & 1B Telford Road | Houndmills Industrial Estate
Basingstoke, Hampshire RG21 6YU
Tel. +44 1256 365 605
info@minitec.co.uk | www.minitec.co.uk

MINITEC FRAMING SYSTEMS LLC (USA)

5602 County Road 41 | 14425 Farmington, NY
Tel. +1 585 9244690 | Fax +1 585 9244821
sales@minitecframing.com | www.minitecframing.com

MINITEC AUTOMATION TECHNOLOGY (USA)

7214 Gateway Park drive | Clarkston, Michigan 48346
Tel. +1 248 620 1820 | Fax +1 248 620 0850
sales@minitecautomation.com | www.minitecautomation.com

MINITEC SYSTEM TECHNOLOGY CO. LTD. (PR CHINA)

Plant No. 10; No. 103 ChengMenJin Road | Taicang 215400
Tel. +86 512 5320 8880 | Fax +86 512 5320 8879
info@minitec.com.cn | www.minitec.com.cn

MINITEC SA (SOUTH AFRICA)

48 York Road, North End | Port Elizabeth 6000
Tel. +27 41 3914795
info@minitec.co.za | www.minitec.co.za



MiniTec-partners worldwide

Australia | Austria | Belgium | Bosnia and Herzegovina | Brazil | Bulgaria | Canada | China | Croatia
Czech Republic | Estonia | Finland | France | Greece | Hungary | India | Italy | Latvia | Liechtenstein
Lithuania | Luxembourg | Malaysia | Mexico | Montenegro | Netherlands | New Zealand | Northmacedonia
Poland | Portugal | Romania | Russia | Serbia | Singapore | Slovakia | Slovenia | South Africa | Spain
Sweden | Switzerland | Turkey | Ukraine | United Kingdom | USA | Vietnam



**SIMPLE SOLUTIONS FOR
COMPLEX CHALLENGES**

With the modular system



PROFILE SYSTEM & LINEAR SYSTEM THE PERFECT BASIS FOR A VARIETY OF APPLICATIONS

The intelligent modular system for mechanical engineering

Aluminium profiles and profile systems have become indispensable in industry, mechanical engineering and automation. The modular MiniTec profile system has already proven its reliability in many different industrial areas. In combination with our linear technology, the modular system is the basis for a wide range of demanding applications in trade and industry. This diversity is what MiniTec customers around the world value and makes MiniTec a leading partner in the industry.



Profile system



Linear technology

Profile series 45 & profile series 30

There is a wide selection of profiles and components available for each application. All components are of high quality, perfectly matched and easy to use. Our aluminium profile series in the 30mm pitch convinces in the lower price segment and is ideally suited for vehicle development or the construction of showcases.

Classic fields of application

From an ergonomic workstation to the prestigious showcase, from stable safety fences to the basic structure of a complex conveyor system or an automated assembly line - flexible and robust, only the designer's imagination limits the possible applications based on the MiniTec modular system.

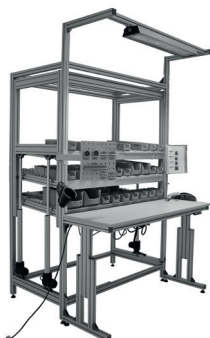

Workplace systems

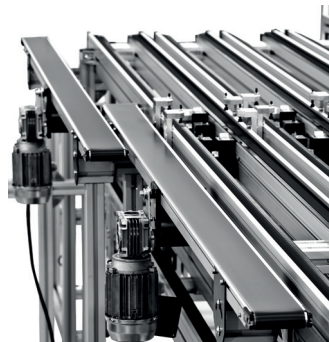

Conveyor technology



Protection systems

SIMPLE SOLUTIONS FOR COMPLEX SYSTEMS INTEGRATED ASSEMBLY SOLUTIONS FROM ONE SOURCE

Tailor-made factory und assembly automation

Our solutions are just as individual as our customers' requirements. As a full-service manufacturer, we use our design system to implement intelligent systems and special machines for a wide variety of tasks in all important industrial sectors: from automotive, chemicals and electrical engineering to energy supply, aerospace, mechanical engineering, the metal and pharmaceutical industries.



left to right.: Nina Huber, Reiner Krück, Peter Müller

Contact

Are you planning a new assembly line or would you like to optimize and automate existing production and manufacturing processes?

Our experts for integrated assembly solutions will be pleased to help!

- E-Mail: solutions@minitec.de
- Phone: +49 (0) 6373 - 8127-247

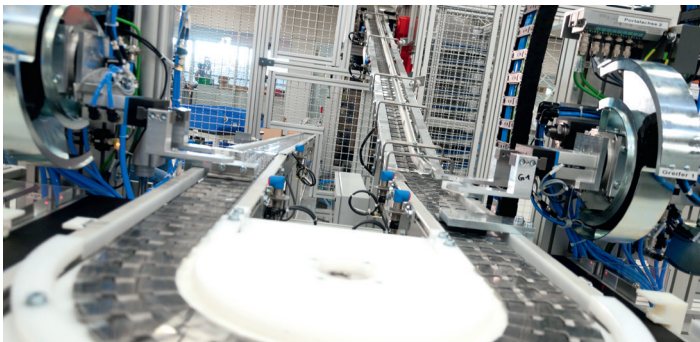

Handling system for flanges incl. workpiece testings

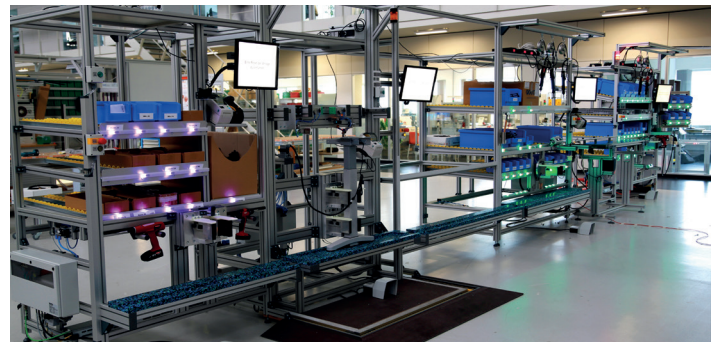

One-Piece-Flow assembly line for office furniture



End of line assembly for truck exhaust systems

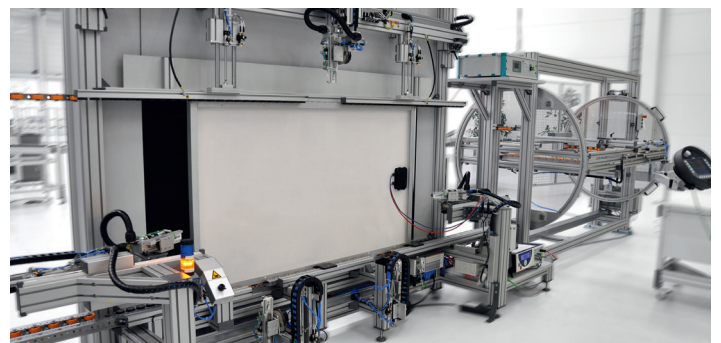

Backend-assembly line for photovoltaic-modules



WE GLADLY ACCEPT YOUR CHALLENGE FROM DESIGNING TO IMPLEMENTATION

Whether simple workstation or complex assembly line: **MiniTec** offers you full service. From consulting and project planning with our own software development to on-site installation.

Our service teams provide fast remote maintenance and regular software updates for trouble-free operation. And if a repair, training or extension is necessary, our experts are also on site in the shortest time.

CUSTOMER SERVICE ON-SITE

14 consulting offices in Germany alone support our customers in problem analysis and develop initial solutions. Our partners worldwide have access to more than 60 bases.

DESIGNING AND ASSEMBLY

More than 30 experienced engineers are constantly developing and testing new components for the **MiniTec**-profile system at the company's headquarters. On the basis of this system, we develop tailor-made solutions for a wide variety of applications after intensive consultation with our customers. The Ergonomics team develops, for example, comprehensive production solutions with workstations,

Kanban production control, pick-to-light picking and electronic operator guidance. All necessary competences from mechanical design to electrical planning, switch cabinet construction, programming, data processing, assembly and installation on site including remote maintenance are available in-house. Our customers benefit from our comprehensive expertise and experience through numerous developments for a wide variety of industries and challenges.



SOFTWARE

Our CAD tool iCAD Assembler is the logical addition to the hardware of our construction kit. Only the combination of hardware and software opens up the full potential for efficient mechanical engineering.

- System independent 3D design tool

- Electronic catalogue
- Direct interfaces to all common CAD systems
- Automatic parts list
- Integrated plausibility check
- Automatic machining drawings
- Configurators for workstations, linear axes, conveyor belts, roller conveyors, protective devices

USER TRAINING

We offer our customers free training courses on individually arranged dates in our company. You will receive valuable tips and tricks to benefit even faster from the advantages of our modular profile system. Among the topics of our free training courses are:

- Selection of profiles and components
- Connection technology without drilling and thread tapping
- The MiniTec linear system: application and combination options
- Workplace design and conveyor technology
- Practical advice on problems of the participants

